

Microstepping Driver

KL7552

Feature

- High performance, cost-effective
- Supply voltage up to +75VDC
- Output current up to 5.2A
- Self-adjustment technology
- Pure-sinusoidal current control technology
- Pulse input frequency up to 300 KHz
- TTL compatible and optically isolated input
- Automatic idle-current reduction
- 16 selectable resolutions, up to 51,200 steps/rev
- Suitable for 2-phase and 4-phase motors
- Support PUL/DIR and CW/CCW modes
- Short-voltage, over-voltage, over-current and over temperature protection

Introduction

The KL7552 is a high performance microstepping driver based on pure-sinusoidal current control technology. Owing to the above technology and the self-adjustment technology (self-adjust current control parameters) according to different motors, the driven motors can run with smaller noise, lower heating, smoother movement and have better performances at higher speed than most of the drivers in the markets. It is suitable for driving 2-phase and 4-phase hybrid stepping motors.

Applications

Suitable for a wide range of stepping motors, from NEMA size 17 to 34. It can be used in various kinds of machines, such as X-Y tables, labeling machines, laser cutters, engraving machines, pick-place devices, and so on. Particularly adapt to the applications desired with low noise, low heating, high speed and high precision.

Electronic Specifications (T_j=25°C)

Parameters	KL7552			
	Min	Typical	Max	Unit
Output current	1.8	-	5.2 (3.7 RMS)	A
Supply voltage	+20	+48	+75	VDC
Logic signal current	7	10	16	mA
Pulse input frequency	0	-	300	kHz
Isolation resistance	500			MΩ

Mechanical Specifications (Unit: mm, 1 inch=25.4 mm)

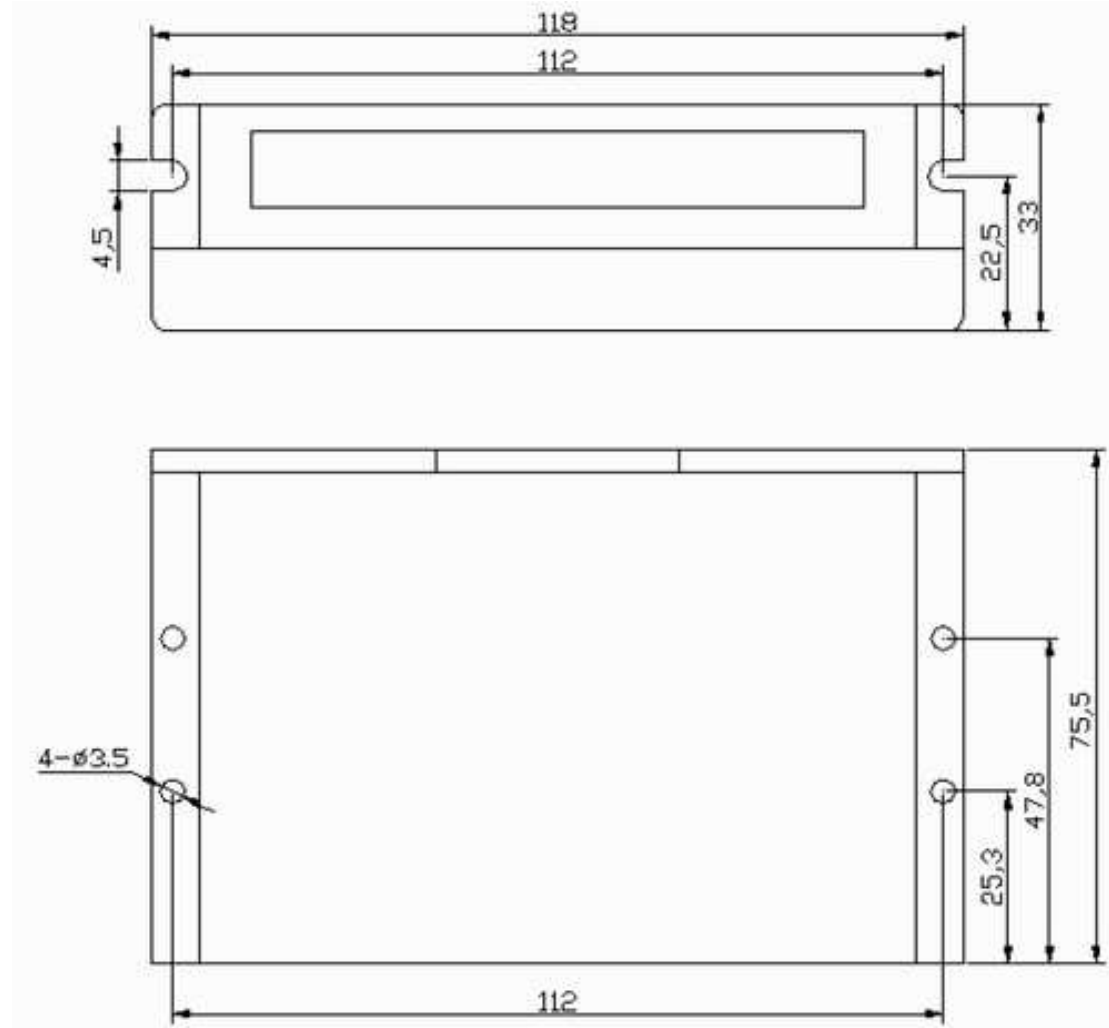

Figure 1: Mechanical Specifications

Pin Assignment and Description

Control Signal Connector P1 pins

Pin Function	Details
PUL+	<p>Pulse signal: In single pulse (pulse/direction) mode, this input represents pulse signal, each rising or falling edge active (set by inside jumper J3); 4-5V when PUL-HIGH, 0-0.5V when PUL-LOW. In double pulse mode (pulse/pulse), this input represents clockwise (CW) pulse, active at high level or low level (set by inside jumper J3). For reliable response, pulse width should be longer than 1.5μs. Series connect resistors for current-limiting when +12V or +24V used. The same as DIR and ENA signals.</p>
PUL-	
DIR+	<p>DIR signal: In single-pulse mode, this signal has low/high voltage levels, representing two directions of motor rotation: in double-pulse mode (set by inside jumper J1), this signal is counter-clock (CCW) pulse, active at high level or low level (set by inside jumper J3). For reliable motion response, DIR signal should be ahead of PUL signal by 5μs at least. 4-5V when DIR-HIGH, 0-0.5V when DIR-LOW. Please note that rotation direction is also related to motor-driver wiring match. Exchanging the connection of two wires for a coil to the driver will reverse motion direction. The default rotation direction can be reverse by inside jumper J2.</p>
DIR-	
ENA+	<p>Enable signal: This signal is used for enabling/disabling the driver. High level (NPN control signal, PNP and Differential control signals are on the contrary, namely Low level for enabling.) for enabling the driver and low level for disabling the driver. Usually left UNCONNECTED (ENABLED).</p>
ENA-	

Power connector P2 pins

Pin Function	Details
+V	Power supply, 20~75 VDC. Including voltage fluctuation and EMF voltage.
GND	Power Ground.
A+, A-	Motor Phase A
B+, B-	Motor Phase B

Microstep Resolution Selection

Microstep resolution is specified by 5, 6, 7,8 DIP switches as shown in the following table:

Microstep	Steps/rev.(for 1.8°motor)	SW5	SW6	SW7	SW8
2	400	ON	ON	ON	ON
4	800	OFF	ON	ON	ON
8	1600	OFF	OFF	ON	ON
16	3200	ON	OFF	ON	ON
32	6400	ON	ON	OFF	ON
64	12800	OFF	ON	OFF	ON
128	25600	OFF	OFF	OFF	ON
256	51200	ON	OFF	OFF	ON
5	1000	ON	ON	ON	OFF
10	2000	OFF	ON	ON	OFF
20	4000	OFF	OFF	ON	OFF
25	5000	ON	OFF	ON	OFF
40	8000	ON	ON	OFF	OFF
50	10000	OFF	ON	OFF	OFF
100	20000	ON	OFF	OFF	OFF
200	40000	OFF	OFF	OFF	OFF

Current Setting

Peak Current	RMS Current	SW1	SW2	SW3
1.26A	0.90A	ON	ON	ON
1.80A	1.29A	OFF	ON	ON
2.36A	1.68A	ON	OFF	ON
2.92A	2.09A	OFF	OFF	ON
3.51A	2.51A	ON	ON	OFF
4.09A	2.92A	OFF	ON	OFF
4.64A	3.32A	ON	OFF	OFF
5.20A	3.71A	OFF	OFF	OFF

Typical Connections

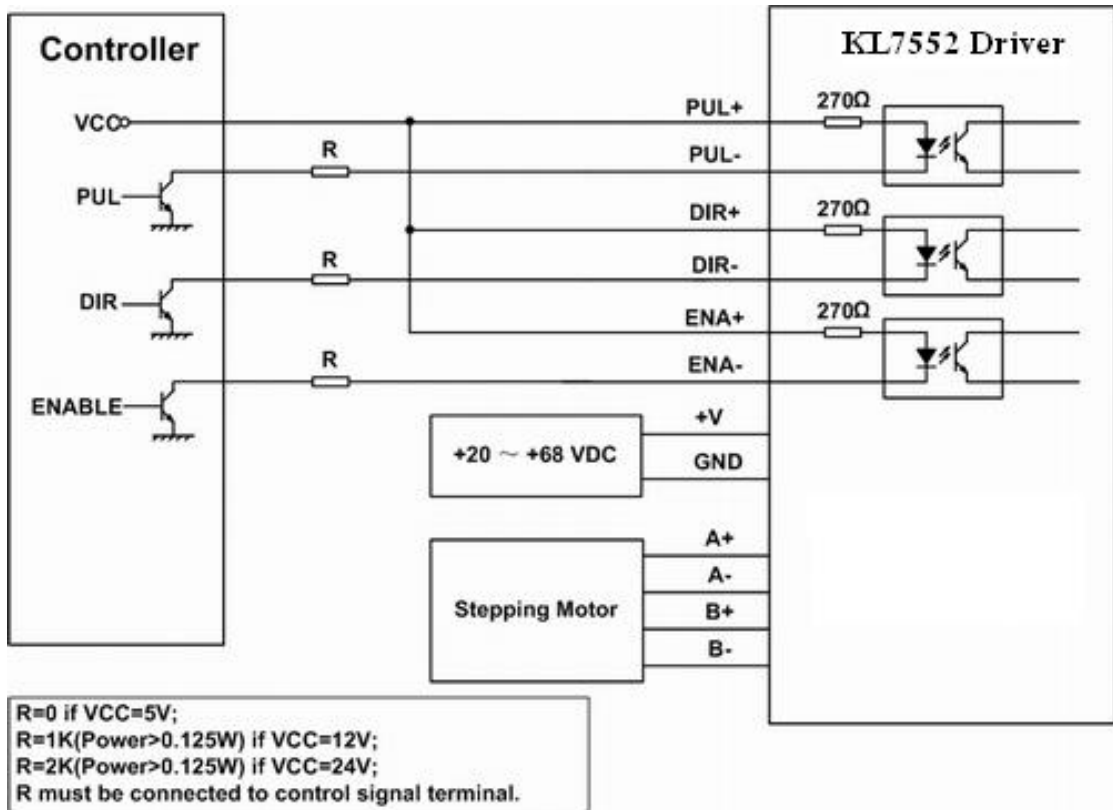

Figure 2: Typical Connections